

Engineering Mechanics and Thermodynamics

ECE 250

Spring 2012

2) The static friction coefficient, μ_s , between a railroad flat car's bed and a load composed of a large block of steel it carries is 0.30. Please determine the minimum stopping distance that the train can have from a speed of 45 MPH with a constant deceleration such that the crate will not slip forward. (200 Points)

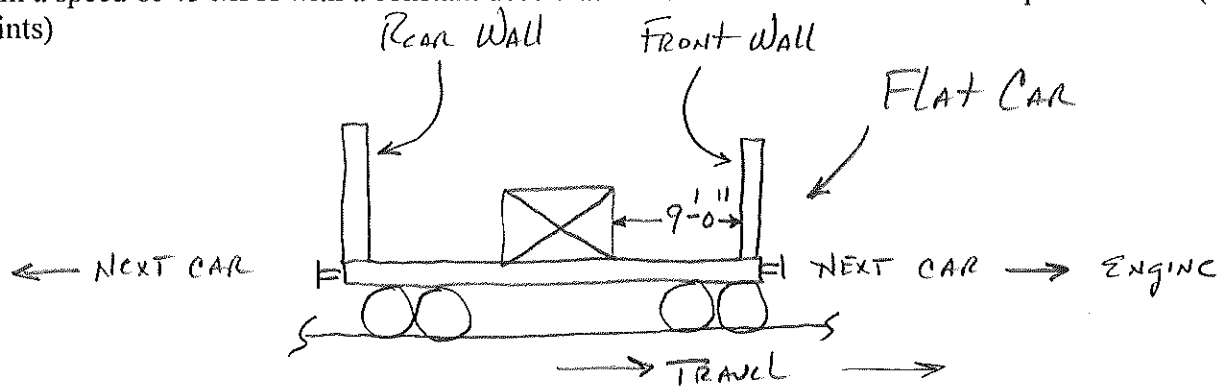

Explanation:

Engineering Mechanics and Thermodynamics

ECE 250

Spring 2012

4) For the friction coefficients of $\mu_s = 0.25$ and $\mu_k = 0.20$, please calculate the acceleration of each body and the tension in the cable (yep, there is only one tension as there is only one cable). (200 and 120 Points)

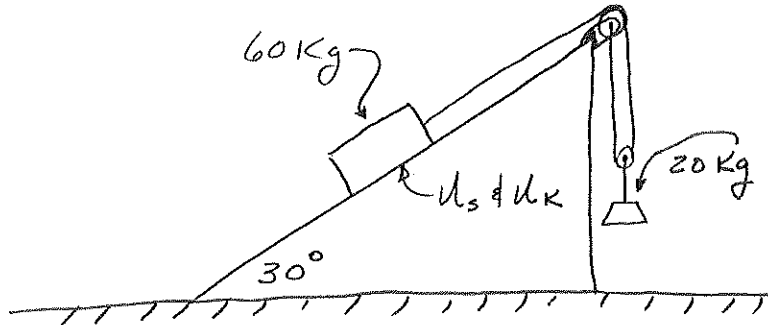

N.B. How the cable is wound over the top frictionless pulley and then through the lower pulley* and then back to the axle of the top pulley!

* Also frictionless

Explanation:

Engineering Mechanics and Thermodynamics

ECE 250

Spring 2012

5) A rocket maintains its horizontal attitude of its let's say "x axis" during the powered phase of its flight at high altitude. The thrust imparts a horizontal component of acceleration of 20 ft/sec^2 , and the downward acceleration component is the acceleration due to gravity which at its altitude is $g = 30 \text{ ft/sec}^2$. At this very same time, the velocity of the mass center G of the rocket along the 15° direction of its trajectory is $12,000 \text{ mi/hr}$. For this position, please determine (a) the radius of curvature of the flight trajectory, (b) the rate at which the speed "v" is increasing, (c) the angular rate of the radial line from G to the center of curvature C and (d) the vector expression for the total acceleration "a" of the rocket. HINT: You will recall from our discussions that the radius of curvature appears in the expression for the normal component of acceleration, so you can use the normal and tangential components to describe the motion of G . (50 and 50 and 50 and 50 Points)

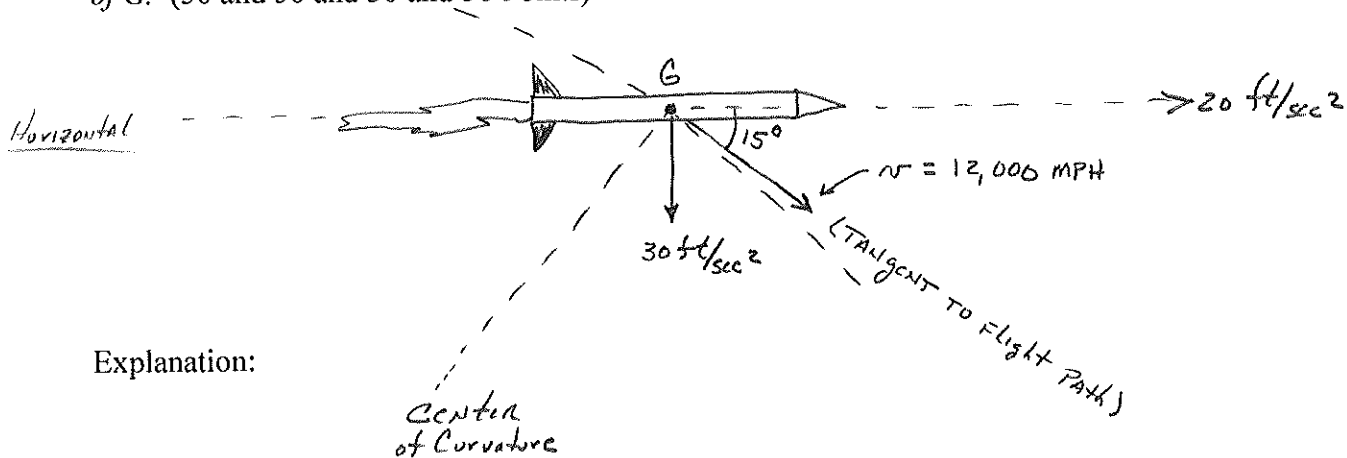

Explanation:

Engineering Mechanics and Thermodynamics

ECE 250

Spring 2012

6) A tracking radar lies in the vertical plane of the path of a rocket which is coasting in unpowered flight above the atmosphere. For the instant when $\theta = 30^\circ$, the tracking data gives $r = 250,000$ ft, $dr/dt = 4,000$ ft/sec and $d\theta/dt = 0.80$ deg/sec. The acceleration of the rocket is due only to gravitational attraction and for its particular altitude G is 31.4 ft/sec² vertically down. For these conditions, please determine the velocity "v" of the rocket and the values of d^2r/dt^2 , the acceleration of the radius from the radar to the rocket and $d^2\theta/dt^2$, the acceleration of the angular direction from the radar to the rocket. (50 and 40 and 50 Points)

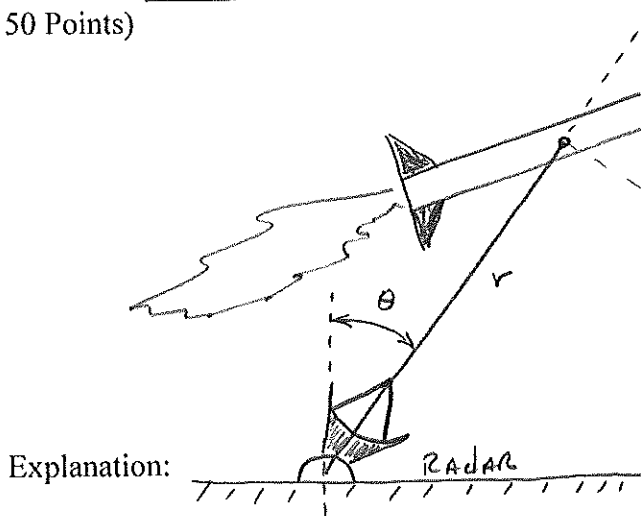

yes it does appear to be quite a substantial rocket and possibly a wee bit close but the data works,