

METHODOLOGICAL NOTES

Can the relativistic change in the scales of length and time be considered the result of the action of certain forces?

To cite this article: E L Fenberg 1975 *Sov. Phys. Usp.* **18** 624

View the [article online](#) for updates and enhancements.

Related content

- [Einstein: the creation of the theory of relativity and some gnosiological lessons](#)
S G Suvorov
- [Expression of the General Properties of Physical Processes in the Space-Time Metric of the Special Theory of Relativity](#)
A A Tyapkin
- [From the equivalence principle to the equations of gravitation](#)
Vladimir P Vizgin and Ya A Smorodinski

Recent citations

- [A constructive approach to the special theory of relativity](#)
D. J. Miller
- [Special theory of relativity: how good-faith delusions come about](#)
Evgenii L Feinberg
- [Einstein: the creation of the theory of relativity and some gnosiological lessons](#)
S G Suvorov

Can the relativistic change in the scales of length and time be considered the result of the action of certain forces?

E. L. Feinberg

*P.N. Lebedev Physics Institute, USSR Academy of Sciences
Usp. Fiz. Nauk 116, 709-730 (August 1975)*

A study is made of the possibility of considering the kinematic effects of the special theory of relativity—the contraction of length of moving bodies and the retardation of the rate of moving clocks—as the result of the action of the forces which hold the body in static equilibrium or which accelerate it during its transfer to another coordinate system. A number of illustrative examples are given.

PACS numbers: 03.30.

CONTENTS

1. Introduction	624
2. A More Precise Formulation of the Problem	624
3. "The Quest for Dynamical Explanations is Meaningless"	627
4. "A Dynamical Interpretation is Possible and even Desirable"	627
5. Commentary on the Contraction of Lengths and the Action of Forces	628
6. The Covariance of the Laws of Nature as an "Integral Limiting Principle"	630
7. Real Processes of Establishing a New Shape of a Body	631
8. The "Dynamical Interpretation" and the General Principles of the Theory of Relativity	633
9. Conclusions	634
Cited Literature	635

1. INTRODUCTION

The question posed in the title of this paper may, of course, be of purely methodological interest. Relativistic kinematics and dynamics form a closed system which makes it possible to solve all correctly formulated physical problems within the competence of the theory. There is generally no need to raise this question when dealing with bodies or coordinate systems in uniform motion. However, when considering changes in the state of motion, particularly in conjunction with physical changes in the structure or other characteristics of the internal states of bodies, one sometimes encounters paradoxes (see Sec. 7 below) connected with precisely the possibility of different answers to the question with which we are concerned. In fact, many physicists who are successfully making use of the theory of relativity and who, it would seem, are well acquainted with this theory, give diametrically opposed answers to this question: some reply affirmatively, while others say that it is not only impossible, but that even the quest for an affirmative reply is itself incompatible with the theory of relativity. To be sure, there is also a very numerous third group who regard the question as being of no interest and of no significance. It is probably for this reason that the question is generally not mentioned in the overwhelming majority of books on the special theory of relativity (we shall discuss only this theory) and, when it is not avoided, there is simply a declaration of one or the other point of view.

With such a sharp divergence of opinions, it is evidently not out of place to consider this problem in greater detail, although the considerations which follow are in essence trivial and may be of purely pedagogical value. At any rate, we are dealing here with the funda-

mental problems of the theory, and it is hardly worth avoiding their discussion in embarrassment.

2. A MORE PRECISE FORMULATION OF THE PROBLEM

We must first of all formulate more clearly the problem with which we shall be concerned.

The length of a rod is a relative concept, and its dependence on the motion of the coordinate system is a reflection of the fact that a length is defined by a relationship of two objects—the body which is measured, and the measuring apparatus of measuring rods and clocks. The length of a particular body which is obtained by using the measuring apparatus placed in some inertial coordinate system is therefore just as real as the measured system, at rest in another inertial system. This stipulation must be made because the question of the dynamical nature of the contraction of lengths is sometimes confused with the question of the "reality of the contraction." It is asked: "Is this effect apparent or real?" Of course, the answer can only be that it is real, since we know of nothing more real than the properties of bodies, which are observed and studied by means of all possible physical methods. Lorentz (in 1912, when he had already fully accepted and understood Einstein's point of view) answered this question as follows: "We should not make the mistake of supposing that the contraction is merely apparent. On the contrary, both A and B [two identical rods, at rest in different systems.—E.F.] can actually be observed . . . just like, for example, the expansion of a body which is heated" (^[1], pp. 27-28; henceforth, wherever foreign-language texts are cited, the translation is that of the present author).

It is perhaps appropriate here to make a small digression to recall that things "appear" to be quite different. For example, we know that, according to the Lorentz transformations, a cube in motion along one of its edges is contracted into a parallelepiped (and a sphere is contracted into an ellipsoid). For a long time, it was universally believed that this would be perceived by an observer as the moving body passes him and, in particular, that the same observation would be made on a photograph. This idea was exploited very effectively in the popular literature; for instance, it was supposed that a passenger in a train moving with very high velocity would see houses and people on the platform as flattened. It was only more than half a century after the creation of the theory of relativity that Terrel^[2] and Penrose (for a sphere^[3]) carried out an unbiased analysis of the problem. It turned out that a cube would still "appear to be" (i.e., would be seen as) a cube (and a sphere would look like a sphere), but that it would appear to be rotated with respect to its original position (more precisely, this is true if the body occupies a small angle of vision). However, in reality it is not rotated, but contracted; i.e., all calculations of effects due to this body must allow for the fact that its matter occupies a contracted, and not a rotated, volume (a parallelepiped or ellipsoid), in uniform motion without a change of shape. The "appearance" is due to the fact that different times are required for the light from different points of the body to strike the eye (or the photographic plate). In particular, the observer therefore sees that side of the body which is not visible to him when the body is at rest.¹⁾ This effect also occurs classically, and relativistic kinematics merely modifies it quantitatively. It is elegantly analyzed in the review^[4].

It is usual, however, to consider only gedanken experiments. Nevertheless, this effect has been long and well observed in high-energy physics. In fact, if two protons of very high energy collide in their center-of-mass system with Lorentz factors $\gamma_C \gg 1$ and produce many new particles, which are emitted on the average with forward-backward symmetry (Fig. 1a), then an observer in the laboratory system sees two forward cones of emitted particles—a "narrow" and a "wide" cone (the angle which divides them being $\theta_{lab} = 1/\gamma_C$), so that an observer looking against the flux of particles sees also those particles which are emitted by the backward hemisphere of the radiating system (Fig. 1b), i.e., he sees, as it were, illumination from the rear surface of the object, which is not visible in the c.m.s., in which the radiating object is at rest.

After this digression about what is "apparent" for various methods of observation and what actually takes place, let us return to our main problem of interest. We

¹⁾Of course, if the length of a thin rod in motion along its axis is measured by the procedure described in Einstein's first paper and adopted since then in all expositions of the theory of relativity, the usual relativistic contraction of the length is observed. To achieve this, the measuring rod must be positioned along the axis of motion in its immediate vicinity (and clocks must accordingly be placed on this axis), and the positions of the ends of the moving rod must be observed simultaneously (according to these clocks) by cameras, eyes, etc., situated in the immediate vicinity of each end of the rod at the moment of its observation. This procedure will be implied in what follows. It is, of course, this procedure which Lorentz had in mind in the quotation. It is precisely in this way, with a proper measuring procedure, that we may observe, for example, the contraction of a sphere into an ellipsoid when it is set in motion.

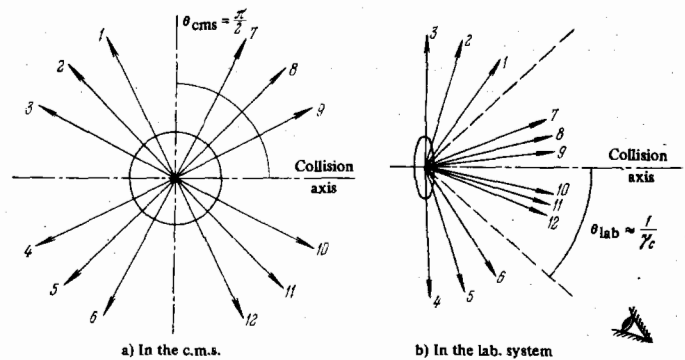

FIG. 1. Meson emission in the process of particle production in hadronic collisions at high energy. a) In the center-of-mass system, b) in the laboratory system. (Half of the particles lie within the narrow cone, $\theta_{lab} = 1/\gamma_C$, where γ_C is the Lorentz factor for the motion of the center-of-mass system in the laboratory system.)

see that it refers in no way to the "reality" of the effect, but to something quite different: does the foregoing quotation of Lorentz imply that the contraction of a length associated with the transformation to another coordinate system may be regarded as the result of the action of certain forces, physical factors or properties of the bodies (bodies (elasticity, etc.) which enter the equations of motion and the equilibrium conditions for parts of the body, in the same way that thermal expansion takes place when heat is supplied in accordance with the equations of heat conduction and mechanics and the final state is determined by the equilibrium of certain forces? This question has no relation to the problem of the ether and is already formulated within the framework of Einstein's theory of relativity.

Let us specify more precisely what is meant by the contraction of lengths and the retardation of clocks.

The usual argument, which was employed by Einstein in his classical paper of 1905, is as follows. "Suppose that in 'stationary' space" (Einstein had already explained here that "stationary" simply refers to one coordinate system which we have selected from among those which we now call inertial.—E.F.) "we are given two coordinate systems... Let each system be provided with a measuring rod and a set of clocks, and let both measuring rods and all the clocks in both systems be exactly identical. Now suppose that the origin of one of these coordinate systems... is given a constant velocity v in the direction of increasing values of x of the other stationary system...; this velocity is also imparted to the coordinate axes, as well as to the corresponding measuring rods and clocks" (^[5], p. 13). The discussion then enters into the usual comparison of measurements in the two systems. Three pages earlier, one also reads that "the rod... is given" (the emphasis is mine—E.F.) "a uniform forward motion (with velocity v) parallel to the x -axis" (^[5], p. 10). This raises the first of two formulations of our problem—the classical formulation, connected with the transfer of the rod and clocks from one inertial system to another. It is a classical formulation in the sense that it is used in the classical works on the special theory of relativity, and also because it is not based on the quantum properties of matter and has a broader significance.

Thus, in this first formulation, the contraction of length which is claimed to occur has the following meaning.^[5,6] Suppose that we have prepared, in some inertial coordinate system ICS_1 , a sufficient number of com-

pletely identical scales of length and clocks, which are then distributed among various inertial systems. Suppose that we have transferred some of them to a system ICS_2 , moving with a velocity v with respect to the first system. By aligning the rods in both systems along the direction of the velocity, positioning clocks at various points of the rods and synchronizing them (in each ICS) by some means, we measure the length of the rod which was transferred to ICS_2 by means of rods and clocks which remain in ICS_1 . It is found that the length of this rod, l_2 , is less than the length l_1 of the same rod before it is transferred to ICS_2 : $l_2 = l_1 \sqrt{1 - (v^2/c^2)}$.

In this case, it is natural to ask whether this has happened because in transferring the rod we had to act on it with certain forces while accelerating it, thereby unavoidably altering something in its structure. For example, we could have pulled it at one end or pushed the other end. Elastic waves will then have propagated along the rod, and, when the applied force was removed and all the parts of the rod attained the same velocity v (in general, these are two distinct conditions; see Sec. 7), it could have had a different form than before the application of the force. It is important to note that we can arrive at the final state of uniform motion with a single velocity v in infinitely many ways. For instance, we can induce an electric charge in the rod and turn on an electrostatic field for some interval of time (of course, the calculation must necessarily allow for the growth and subsequent decrease of the field which is switched on and off, in both time and space), etc. All such processes of setting the rod in motion involve a possible change in its deformation according to very different regimes (in particular, we can set the rod and clocks in motion infinitely slowly; however, this does not mean that the integrated effect vanishes).

In endeavoring to account for the Lorentz contraction in this way, we immediately encounter two embarrassing points in this argument.

First, it seems very strange that all the possible processes and regimes of deformation that end with uniform motion with the same velocity v lead in the final analysis to the same resultant deformation, namely a Lorentz contraction depending only on v .

Second, instead of accelerating the measured rod by bringing it into ICS_2 , we could accelerate the entire measuring system which is set up in ICS_1 by giving it the same velocity, but in the opposite direction. According to the theory of relativity, the same result should be obtained—as, of course, it is: there is a contraction of the measured rod, even though the forces have acted not on the rod, but on the system of measuring instruments.

However, these are merely doubts, and corresponding counter-arguments, which we shall give below, can be found against each of them.

But there exists another formulation, which avoids the procedure of transferring the bodies, although in essence it makes use of the identity of micro-particles, in particular of atoms of one and the same element, i.e., it makes use of quantum properties.

This formulation frees us from the procedure of transferring the bodies. In this case, there is no discussion of the acceleration of a body, but one immediately considers the equilibrium configurations of two identical bodies, each at rest in its own ICS. For example, we prepare identical rods, "say, of steel" ⁽¹⁾,

p. 211), independently in two ICSs, in which case "the only initial difficulty is the problem of how to adopt... the same standards of length" (ibid.). However, this difficulty can be overcome.⁽¹⁾ It should be stressed that we are (implicitly) adopting the very natural assumption here that the "steel" is identical in the two systems. In essence, we are relying ultimately on the quantum principle of the identity of micro-particles and atoms (isotopes) which are identically constructed from them. Thus, two atoms of cadmium placed in different ICSs can, a priori, be considered identical. At the same time, by comparing (by means of instruments in any one ICS) the wavelengths and frequencies of the radiation emitted by them, we observe the relativistic variations of these quantities (see, e.g., ⁽⁷⁾). The two approaches lead to the same results, and this is, of course, essential.

In fact, when we observe a rod which moves with velocity v , we may not know its history;⁽²⁾ it may have been either transferred from ICS_1 to ICS_2 or prepared directly ("from the same material") in ICS_2 . The result cannot depend on our knowledge or ignorance.

Of course, in this second formulation, the validity of the transformation formulas of the theory of relativity are made to depend on the quantum principle of the identity of micro-particles. This may be considered undesirable, since the theory of relativity is generally assumed to be of universal validity, independently of the particular principles of quantum theory. However, most physicists consider the "identity" of the matter of steel, etc. such an elementary and obvious fact that it is difficult to find a weak point in this argument.⁽³⁾

However, this second formulation, like the first, does not in any way rule out a "force" interpretation of the contraction of lengths. Having transferred a rod, we can assume that, once the external forces have ceased to act, certain stresses remain in the rod and a new equilibrium of the internal forces has been established, determining its new form. Consequently, a rod prepared directly in ICS_2 and having the same contracted (from the point of view of ICS_1) form must involve precisely the same equilibrium of forces, without its being transferred. This is actually so. Without knowing anything about the history of the moving rod, we can measure the forces which are acting inside it and convince ourselves that they are quite different than in the rod at rest. For example, the intensity of the electric field of each moving charge of which the rod is composed is different from that of the same charge at rest. Moreover, it has a magnetic field, which is absent for a stationary charge and which can also be measured. Therefore, if two charges are moving together, different forces are acting between them than when both charges are at rest. Hence the equilibrium form of a body composed of charged particles must also change.

²⁾To be sure, we must be certain that its parts are in a stationary state, i.e., that any external forces which have acted on it were applied sufficiently far in the past; see Sec. 7.

³⁾This does not, of course, exclude the following very interesting situation: perhaps it is not possible to satisfy the principle of relativity in a world in which matter is not subjected to quantum laws. In fact, quantum theory and the theory of relativity are very intimately related. For example, the identity of particles, which is taken as an independent postulate in nonrelativistic quantum mechanics, must actually be a consequence of second quantization in a consistent relativistic quantum field theory.

Of course, the same puzzle arises here as in the case when the rods are transferred: why, regardless of the nature of the forces and the material, as well as the shape and position of a body, does the new equilibrium form differ from the form of this same body at rest by one and the same Lorentz contraction, which depends only on the velocity of its motion v ? However, this is again only a doubt, and the universality of the contraction as a consequence of certain forces can be asserted at the present time for at least two particular types of fields—the electromagnetic field and the field of elastic forces (see below).

The two formulations which we have given are distinguished (in a sense which is of interest to us here) by the fact that in the first case we are concerned with what might be called a “dynamical” interpretation of the relativistic contraction, while in the second case we are dealing with a “static” interpretation; but both cases involve not “kinetic” arguments, but the concept of the forces which are actually acting.

Before turning to the question of whether such an interpretation is physically admissible, it is appropriate to cite the opinions of various authors on this problem.

3. “THE QUEST FOR DYNAMICAL EXPLANATIONS IS MEANINGLESS”

We give here a random selection of quotations from generally good popular books and from more serious books of various authors who are evidently acquainted with the theory of relativity and competent to apply it in practical calculations. Some of these authors are well-known scientists.

“Moving bodies are contracted in their dimensions, not because of any intrinsic changes which occur in them, but simply because they are in motion with respect to the measuring apparatus. This effect is not dynamical, but purely geometrical, or, more precisely, kinematic” (^[8], p. 40). “Needless to say, the quest for dynamical explanations of the time dilation is just as meaningless as in the case of the Lorentz contraction” (^[8], p. 49).

“For Lorentz and Fitzgerald the contraction was a physical change due to the pressure of the ether wind. For Einstein it was due only to the measuring process” (^[9], p. 56). Obviously, if it is due “only to the measuring process” (which, as we shall soon see, Einstein actually believed), we can infer that the author rejects not only an interaction with the ether, but also a deformation depending on the action of the forces of acceleration in transferring the measuring rod.

“If . . . , we can draw the false conclusion that something like a physical Lorentz-Fitzgerald contraction occurs with moving clocks” (^[10], p. 111). Thus, no “physical” contraction occurs.

“The work ‘contraction’ may suggest a totally incorrect interpretation of this term. Thus, a rod expands when heated and contracts when cooled. Nothing of the sort happens (from the point of view of Einstein’s theory) to either the train or the platform when they are in relative motion” (^[10], p. 128; cf. the quotation of Lorentz given earlier in Sec. 2).

“Kinematic effects should not be denied on the grounds that they occur in the absence of real forces.

In fact, the relativistic contraction of lengths is not due to any such forces” (^[11], p. 176).

In some books translated from the English, the change of length and retardation of time are called “apparent.” However, it must be borne in mind that the English word “apparent” need not have the same connotation “fictitious” as its Russian equivalent. Thus, in the book ^[12] we find: “Hence the apparent length of the rigid body . . . is reduced” (p. 15), “A moving clock appears to go slow” (p. 16), etc. As no further amplification of these phrases is given, we cannot assume, in all fairness, that the author is denying the dynamical nature of the effect, although this does seem plausible.

To this we may add that the present author has often been obliged to hear theoretical physicists for whom he has great respect give the same answer to the question under consideration here: it is not only impossible to invoke a picture of forces which bring about the contraction of a rod and change in the rate of a clock, but this is incompatible with the entire spirit of the theory of relativity.⁴⁾

It is not superfluous to stress that the whole fervor of the argument of the authors who stand on the “anti-dynamical” or “anti-force” platform is generally directed against the ether and against the belief that rods are changed in being transferred from absolute rest to “real” inertial motion. Actually, the old and long obsolete question of absolute motion has no relation whatsoever to what is of interest to us here. We are discussing processes which take place within the scope of the usual definition of length and procedures of measurement in the theory of relativity, i.e., we are already rejecting Newtonian absolute space.

4. “A DYNAMICAL INTERPRETATION IS POSSIBLE AND EVEN DESIRABLE”

The fascination and strength of Einstein’s treatment, as expressed in his celebrated first paper,^[5] created such an overwhelming impression that many readers neither saw nor heard certain interesting opinions of a number of authors who, let us say at once, are quite serious.

Pauli: “It is highly significant that Einstein rendered the theory independent of any special assumptions about the structure of matter.

“Should we completely abandon the quest for an atomic understanding of the Lorentz contraction on these grounds? In our opinion, we should not. The contraction of lengths is not a simple process but, on the contrary, is extremely complex. It would not take place if the basic equations of electron theory, as well as the unknown laws determining the structure of the electron, were not covariant with respect to the group of Lorentz transformations. We must even postulate that this is the case (Wir müssen eben postulieren dass dies der Fall ist) and bear in mind that, when these laws become known, the theory will be in a position to provide an atomic explanation of the behavior of moving rods and clocks” (^[13], p. 30; the emphasis is mine.—E.F.).

⁴⁾For some reason, the controversies which relate to the problems in understanding the basic principles of the theory of relativity and of quantum mechanics usually take a particularly acute form. They often “become personal,” with mutual accusations of ignorance, etc.

Now perhaps this is merely a reservation by the young author—indeed, Pauli was 21 years of age when he wrote his remarkable book. However, Einstein warmly endorsed it as “a mature and carefully thought-out work”,^[14] It is difficult to regard this approval as the result of some carelessness of Einstein, who perhaps did not attach any significance to the opinion of Pauli quoted above. Indeed, in a brief and even highly favorable review of Weil’s book, he did not fail to express his disagreement with Weil’s points of view about the meaning of the law of conservation of energy and about the relationship between theoretical physics and reality.^[15]

Another author, von Laue: “The elastic forces which govern the shape of a body must be affected by its motion in such a way that they lead to a contraction” (^[16], p. 62).

A third author, Möller: “It should also be possible to derive the retardation of a moving clock from the fundamental laws of mechanics which govern the rate of the clock. But just as in the case of the Lorentz contraction, it is more satisfactory to consider the retardation effect as an elementary effect which is an immediate consequence of the principle of relativity. If we base our calculations of the operation of a clock on Newtonian mechanics, we do not obtain any retardation when the clock is in motion, since time is an invariant parameter in Newton’s basic equations . . . However, this shows that Newton’s equations are not sufficiently accurate in the domain in which $\sqrt{1 - (v^2/c^2)}$ is appreciably different from unity. If we use the exact relativistic equations of mechanics to describe the operation of a clock . . . , the retardation effect must be obtained as a consequence of these equations” (^[17], pp. 49–50; the emphasis is mine.—E.F.). Thus, according to Möller, there is only the question as to what is to be considered more “elementary” and satisfactory—the retardation due to the dynamics of a material system (a clock) which is set in motion, or the generally kinematic derivation from the principle of relativity. He prefers the second alternative, and this choice is understandable (see below). Now what did Einstein himself believe?

“Strictly speaking, the theory of rods and clocks would have to be derived by solving the basic equations (assuming that these objects have an atomic structure and are set in motion) and should not be assumed to be independent of them”.^{[18]5)}

5. COMMENTARY ON THE CONTRACTION OF LENGTHS AND THE ACTION OF FORCES

Having cited so many quotations which express both points of view, we can now dispense with the poorly maintained standards of objectivity and present a some-

⁵⁾Further: “The usual method of proceeding has its justification, however, since it is clear from the outset that the postulates adopted as a basis for the theory of rods and clocks are inadequate. These postulates are not so strong that they could be used to derive sufficiently complete equations of motion for physical processes. If we do not completely abandon the physical interpretation of the coordinates (which in itself would be possible), it is better to admit this inconsistency, but with a commitment to eliminate it in the subsequent development of the theory [the emphasis is mine.—E.F.]. However, this sin cannot be absolved to such an extent as to allow us, for example, to use the concept of distance as a special sort of physical entity which is essentially different from other physical quantities (to reduce physics to geometry, etc.).”

what more detailed commentary upon and motivation for the point of view that it is possible to achieve a dynamical understanding of the contraction of lengths; then, in the next section, we shall show how this approach compares with the more widely adopted kinematic approach (which, as we shall see, can be considered in a certain sense to be even more satisfactory in the case of bodies with a constant velocity and fixed structure).

In giving the two formulations of the physical realization of the process of contraction of length in Sec. 2, we also quoted possible objections against the “force” interpretation. One of them is common to both formulations: how can one reconcile this interpretation with the fact that, whatever the regimes of acceleration and the nature of the forces and the material, etc., the final result is universal—the result depends only on the final relative velocity v ? A second objection refers only to the procedure of transferring the rod: why does the action of the measuring system on the rods and clocks cause a contraction of the measured rod?

Let us first consider this second objection.

The reader may observe that it is formulated here slightly differently than in Sec. 2, although completely equivalently. This change in the formulation is sufficient to make the answer almost trivial: clearly, if the measuring instruments are changed somehow under the action of forces, then the result of the measurement may be changed.

Suppose, for example, that instead of transferring the measured rod from ICS_1 to ICS_2 , which is in motion with velocity v , we transfer the measuring rod and clocks from ICS_1 to some new system ICS_3 , which is in motion with respect to ICS_1 (and with respect to the measured rod of length l_1 , which remains in this system) with the opposite velocity $-v$. Obviously, from the point of view of ICS_1 , the length of the measuring rod (as in the first variant, in which we transferred the measured rod to ICS_2) must become smaller by the same factor as before, i.e., $l_1'' = l_1 \sqrt{1 - (v^2/c^2)}$. However, this does not in any way imply that the measured rod which remains in ICS_1 becomes longer than the measuring rod from the point of view of ICS_3 (which would contradict the first case and break the symmetry). In fact, we must also consider what has happened to the clocks in transferring them to ICS_3 ; indeed, they also play a role in measuring the length of the rod which remains in ICS_1 . Suppose, for example, that in accelerating the measuring rod (to velocity $-v$) we have pulled it at the end which was initially at the point $x_1 = 0$. Elastic waves propagate along the rod and up to a clock at some point $x_1 \neq 0$; they arrive after some time proportional to x_1 , and it is only then that this clock begins to accelerate and can start to change its rate. The time which this clock reads, t_3 , after the acceleration process has been completed will therefore be some function not only of t_1 , but also of x_1 . We can ensure that the principle of relativity is satisfied and that there is no dependence on the regime of acceleration if this function is linear, with coefficients which depend only on the final velocity v :

$$t_3 = \alpha_1(v) x_1 + \alpha_2(v) t_1. \quad (1)$$

Similarly, for the point of the rod which was initially at $x_1 \neq 0$ and which begin the acceleration process only when the front of the elastic wave reached it, we have in general

$$x_3 = \beta_1(v) x_1 + \beta_2(v) t_1. \quad (2)$$

It is now easy to satisfy the requirement of reciprocity, the validity of the principle of relativity (and, in general, the group properties), by choosing the corresponding functions $\alpha_i(v)$ and $\beta_i(v)$ in exactly the same way that Einstein did and is done in all courses on the theory of relativity.

Thus, the above-mentioned doubt can be eliminated.⁶⁾

One may naturally still wonder why a symmetric result is obtained when there is such an enormous asymmetry in the transition to the final state of motion with the same relative velocity. But we should recall here that Einstein's fundamental paper^[5] begins with precisely this problem: Maxwell's theory provides an asymmetric description of the "interaction between a magnet and a conductor," but the physical result is symmetric. "The observed effect here depends only on the relative motion of the conductor and the magnet, whereas the two cases in which one or the other of these bodies is in motion should be strictly distinguished according to the usual treatment. In fact, if the magnet is in motion and the conductor is stationary, an electric field is induced around the magnet... But if the magnet is at rest and the conductor is in motion, there is no electric field around the magnet; on the contrary, an electromotive force is induced in the conductor." Thus, the physical effect acts on different bodies, but the result is the same and corresponds to a genuine symmetry, which is revealed in the theory of relativity. It is important to observe here that Einstein does not at all assume that the "usual" asymmetric treatment is incorrect and gives an erroneous description of the phenomenon in either of the two cases. It yields the correct behavior of the physical effects in accordance with the equations of motion, does not lead to erroneous conclusions and is admissible, but it does not reveal the full depth of the phenomenon and leaves obscure the identity of the results of such different processes.

We turn now to the first "objection," which applies to both the classical formulation of the problem, involving the transfer of the rods and clocks, and the formulation which is independent of this transfer, based on the identity of micro-particles and atoms: why does the final effect not depend on the regime of acceleration, the type of force, the shape of the body or the properties of matter, but only on the final relative velocity v ? Let us consider an illustrative example. This is the example of the universally well-known Lorentz solution of Maxwell's equations for the field of a point charge. Prior to any theory of relativity, Lorentz showed that the spherically symmetric Coulomb field of a charge becomes ellipsoidal when the charge is put into a state of uniform and rectilinear motion. Despite the accompanying phraseology, the essence of the matter here bears no relation to the existence of the ether. It is important to emphasize two properties of the solution which is found: 1) the result is independent of the method and regime of acceleration which leads to the final state of uniform and rectilinear motion; 2) the result coincides exactly with what is obtained by applying the theory of relativity, i.e., the principle of covariance of the equations of electrodynamics with respect to Lorentz

⁶⁾It may be asked why a clock which is set in motion may begin to change its rate and go slow, for example. The answer depends on the specific construction of the clock. For instance, a clock involving a weight on a spring may be affected by the growth of the mass with velocity ([19], p. 26; this possibility may also have been pointed out by someone else).

transformations or, if one prefers, relativistic kinematics.

This was possible before the formulation of Einstein's theory of relativity because Maxwell, four decades earlier, performed the miracle of discovering the equations of electrodynamics, which are directly invariant under Lorentz transformations.

Lorentz inferred from his result that, if the elements of bodies were held in equilibrium by electromagnetic forces alone, they would accordingly arrange themselves at new equilibrium points (for example, on the ellipsoidal equipotential surfaces) and the characteristic Lorentz-Fitzgerald contraction would take place for macroscopic bodies as a whole.⁷⁾

However, it is well known that such an equilibrium is not possible under the action of electromagnetic forces alone (Earnshaw's theorem in electrostatics, the instability of the structure of the electron itself, and the fall of the electron into the nucleus in the non-quantum orbital model of the atom). There must therefore exist some other principles which guarantee equilibrium. But the equations of motion for the laws of mechanics, the theory of elasticity, etc. were known at that time only in a nonrelativistic form (which is incorrect for large v). They could not be transformed in the same way as the electromagnetic equations and could not, in conjunction with the latter, ensure the correct Lorentz contraction of a macroscopic body as a whole.

In the quotation cited earlier, Möller stressed that, if the rate of a clock is described by the correct relativistic equations of mechanics, the correct retardation of the clock must also be obtained in a dynamical calculation (i.e., in the same way that Lorentz obtained the contraction of an electric field).

We may imagine the following fantastic situation. Let us suppose that mankind were at the same time both very stupid and very clever and that, in particular, the theory of relativity, with its new interpretation of space and time, had not been created, either in 1905 or in the following decades; but suppose that, on the other hand, by studying faster and faster motions, physicists were able to discover that Newton's laws of motion were incorrect. For example, they might have discovered that, in using Newton's laws, one must assume that mass varies with velocity (this actually happened historically), that masses are different for longitudinal and transverse acceleration, and that the components of a force (measured in a system with respect to which a body is in motion) generally act in an "unusual" manner. Then, by proceeding purely empirically and generalizing experiment, some new Maxwell—a "Maxwell No. 2"—at last might have formulated, to use contemporary terminology, a relativistically correct generalization of Newton's laws, i.e., he would have done what the "Maxwell No. 1" achieved for electrodynamics, again without having any notion of either the covariance of the equations or the principle of relativity (and even being firmly convinced of the existence of the ether).

Suppose further that some years had passed and that,

⁷⁾The argument based on Lorentz's solution is therefore also valid for the formulation which does not involve the transfer of the rod: as we have already pointed out, one can measure the new values of the electric field intensity and convince oneself that this new picture of the forces guarantees equilibrium.

by studying multiple particle production in hadronic collisions at ultra-high energy, somebody decided to describe it as Landau did in 1953 (see below), i.e., as a hydrodynamical process, and that a detailed study of the process led some "Maxwell No. 3" to the idea that the equations of hydrodynamics can be written in the form

$$\frac{\partial T_i^k}{\partial x^k} = 0 \quad (i = 1, \dots, 4, x^4 = ct), \quad (3)$$

in which the energy-momentum tensor must be taken to be

$$T_i^k = (\epsilon + p) u^k u_i + p \delta_{ik} + \tau_i^k, \quad (4)$$

where u^k is what we now call the 4-velocity, ϵ is the energy density, p is the pressure, and τ_i^k is a term describing the effect of viscosity and thermal conductivity (this term, which is now well known—see, e.g., [20]—is a complicated combination of the 4-velocity u^k , the two coefficients of viscosity and the coefficient of thermal conductivity; in general, the right-hand side of Eq. (3) contains the external force).

Suppose that further decades had passed and that mesons and mesonic forces were discovered, and that, after disturbing extensive investigations (particularly disturbing without the knowledge of the principle of covariance), some "Maxwell No. 4" succeeded in writing down the correct relativistically covariant (without the realization of this fact by physicists) equations for the meson field. All this might have been repeated later for the weak interactions. As a result, it would have been found that all these fields lead in a remarkable way to one and the same Lorentz deformation in the presence of motion (for example, according to the correct hydrodynamics (Eqs. (3) and (4)), an initially spherical liquid drop becomes ellipsoidal), i.e., they lead to the same contraction of the linear scales of all these fields along the direction of motion and to the same retardation of temporal processes associated with these fields.

All this would have been a "force" or "dynamical" description of the most diverse fields and processes, and this would not have been incorrect, but their disconnectedness would be unsatisfactory and the fact that the states of uniform motion lead to identical kinematic consequences would be completely inexplicable.

However long this process might have lasted, the understanding of these general properties would inevitably have led to the discovery of the principle of covariance and to the realization of the peculiar properties of space and time, which are revealed by an analysis of the measuring process. The genius of Einstein was that the experience of electrodynamics and Maxwell's equations was sufficient for him to carry out this work (however, as is well known, he himself said that if he had not done this, then someone else would "before long" have formulated the special theory of relativity,⁸⁾ and mankind would not have been as stupid as is assumed in the foregoing—logically possible—fantastic story).

⁸⁾With justification, he added here: "But the situation is different as regards the general theory of relativity. It would hardly have been known today" (this was said a quarter of a century after it was published).

6. THE COVARIANCE OF THE LAWS OF NATURE AS AN "INTEGRAL LIMITING PRINCIPLE"

We now have a good understanding of why the result is the same for all fields: the equations of motion for all fields describe processes in space-time, whose metric is determined by one and the same process which we have adopted for measuring lengths and intervals of time, and these equations of motion are covariant with respect to one and the same Lorentz group. Consequently, those general properties of material bodies and processes for which it is sufficient to take into account these properties of space-time are obtained in this way not only more easily, but also in a more satisfactory way, than by analyzing the dynamical process of the transformation (deformation) of bodies in transferring them to a moving coordinate system (it is immaterial whether the measured body is transferred to another ICS or the measuring instruments are transferred to an ICS moving in the opposite direction with the same velocity). It is for this reason that Möller, for example, in the quotation cited earlier, is justified in considering the approach based on the general kinematic principle to be more satisfactory and the contraction of length which follows from it to be a more "elementary" fact.

However, the theory of relativity does not in any sense replace or supersede the equations of motion—it only "controls" them. Einstein repeatedly discussed this point: "The general principle of the special theory of relativity is contained in the postulate that the laws of physics are invariant under Lorentz transformations... This is a limiting principle... which may be compared with the fundamental thermodynamic limiting principle that perpetual motion does not exist" ([18], p. 279; the emphasis is mine.—E.F.). Elsewhere, he again places it on an equal footing with the law of conservation of energy and the law of non-decreasing entropy. Let us consider this as an example.

Suppose that a student is given the (nonrelativistic) problem of finding the height z_0 to which a stone of mass m would rise if projected upwards (along the z -axis) with velocity v . A careful but not very ingenious student would write down Newton's differential equation of motion, solve it subject to the initial conditions $z = 0$ and $\dot{z} = v$ at $t = 0$, determine the function $z(t)$, and find z_0 by maximizing this function. He has the right to proceed in this way. Everything is physically and mathematically correct here. However, this procedure is not at all necessary. Indeed, without solving the equation, one can immediately state, by using only the law of conservation of energy, that $gz_0 = mv^2/2$ (where g is the gravitational acceleration), and one need not be interested in the function $z(t)$.

This problem can be complicated, for example, by adding a horizontal wind. The solution of the differential equation becomes more complicated and a two-dimensional trajectory would be calculated, but z_0 can again be determined instead directly from the law of conservation of energy for the vertical component. But what if we assume that a tornado with strictly horizontal winds is situated in the region of the experiment? This complicates the calculation of the entire trajectory even more (we are assuming, of course, that the student is so slow-witted that he does not confine himself to solving a single equation for $z(t)$, but calculates the entire three-dimensional trajectory), but all this is unnecessary—as before, the

law of conservation of energy gives the required (limited in content) answer at once. The same applies if the stone is projected from a horizontally moving train, etc.

We stress two circumstances in this example: 1) the infinite diversity of trajectories obtained for the various formulations of the problem all lead to the same answer to the question of interest to us, namely $z_0 = mv^2/2g$ (although there are, of course, other formulations of the problem which violate this result, for example if there is a vertical component of wind velocity); the chemical composition and the shape of the stone are also both immaterial here; 2) the actual physical principle which limits the height of the trajectory of the stone and determines z_0 is the law of conservation of energy. Therefore, a solution based on this law is not only simpler—it is also more satisfactory. However, it does not in any way forbid the use of differential equations; it does not make this physically incorrect and absurd. The equations of motion may be used to follow in a continuous way the flight of the body up to z_0 . One can, in general, obtain many physical results which cannot be derived from the single law of conservation of energy. These results can be completely different for different formulations of the problem and for different regimes of attaining the same height z_0 . But this is clearly inappropriate for answering our narrow question (of finding only z_0). Moreover, a detailed solution obscures the real physical nature of the effect.

It is easy to see that the foregoing example is completely analogous, point by point, to the problem of the dynamical nature of the contraction of rods and retardation of clocks.

If we are interested only in the relationship between lengths of bodies or intervals of time in two different ICSs, there is no need to analyze all the stages of the dynamical deformation of rods in transferring them from one ICS to another, just as there is no need to analyze the static equilibrium of the forces in each particular body of a complex configuration (if we adopt the formulation which does not involve the transfer of the rod). For this problem, which is very limited in its formulation, 1) the regime of acceleration is immaterial, and there is a unique result depending on the final constant velocity which is reached; 2) the profound physical principle which in essence determines the final effect, just as the law of conservation of energy limits the height of the trajectory of the stone, is the absence of a preferred coordinate system and the existence of a space-time continuum which cannot be decomposed into independent continua of space and time. The solution based on these "kinematic" arguments is therefore not only simpler, but also more satisfactory.

Let us make one further remark. The law of conservation of energy was previously deduced as a generalization of experiment and, in mechanics, as an integral of the motion. We now interpret it as a consequence of the homogeneity of time, which is reflected in the invariance of the Lagrangian function with respect to displacements in time. Similarly, although the principle of relativity might be derived from the system of covariant equations for all the fields, if these equations were known, it does not merely express the mathematical covariance of the equations of motion, but it can be interpreted as a manifestation of the properties of space-time. It is for this reason that we are justified in regarding the kinematic calculation as "more elementary,"

as Möller puts it. At the same time, nothing prevents us from considering the equations of motion to be generally more fundamental than the law of conservation of energy (indeed, the latter is one of the particular consequences of the equations of motion), and the same is true for the theory of relativity (cf. the foregoing remark of Einstein that "the theory of rods and clocks would have to be derived by solving the basic equations").

7. REAL PROCESSES OF ESTABLISHING A NEW SHAPE OF A BODY

Now why all this complication—would it not be simpler to forget about the possibility of a dynamical analysis and to forget about the existence of this very problem? In spite of everything, it seems that this is not so.

It would be desirable in itself to understand the true relationship between the physical process of gradually changing the contraction of bodies and the retardation of the rate of processes in accordance with the action of accelerating forces, or between varying conditions of equilibrium of the forces in a moving body on the one hand, and, on the other hand, the general space-time regularities which ensure the validity of the principle of relativity. At the same time, we might expect that an understanding of these problems should be of pedagogical value, since it would relate the rather abstract concepts of the theory of space-time measurements to the very "mundane" and "physically apparent" phenomena of deformation. For those who are studying the theory of relativity for the first time, it may be expedient to begin its development with the contraction of the Coulomb field as Lorentz derived it, emphasizing the fact that the degree of contraction is independent of the particular character of the acceleration process; one can then introduce the necessity of a similar transformation for all other fields, postulating that absolute motion cannot be observed (the principle of relativity); to ensure that this is so, one can accordingly require the reciprocity of the contraction of bodies and introduce the condition that a measured length is identically contracted when it is not the measured rod but the measuring system of rods and clocks which experiences the action of forces (and acquires an acceleration). Only after it is qualitatively (not necessarily quantitatively) understood in this way that the results are independent of not only the regime of acceleration, but also the choice of the object on which the force acts, one can compare this situation with the asymmetry in the interpretation of the interaction between a conductor and a magnet (with which Einstein's paper began) to formulate the general problem of measurement, giving the usual result concerning trains and platforms. This treatment may be clearer and may to some extent dispel the mystery which surrounds the Lorentz contraction and retardation (it must be confessed that, with the universal dissemination and utilization of the theory of relativity, very many people "understand nothing in the beginning but become accustomed to it in the end").

But this is not enough. If we encounter real processes which involve the interaction of bodies and fields and which lead to a redistribution of the velocities of the bodies, etc., and if, as happens more and more frequently, we are interested in the course of a real process of accelerating a body to relativistic velocities, then we cannot dispense with the equations of motion. In such cases, apart from purely computational problems, we often en-

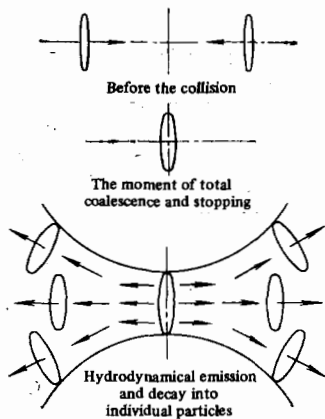

FIG. 2. Multiple hadron production in collisions of nucleons of very high energy according to Landau's hydrodynamical theory (the picture in the overall center-of-mass system).

counter a situation in which the elucidation of the reality of the dynamical process is essential for an understanding of the studied process. Conversely, such phenomena reveal, for example, the reality of the nature of the contraction in terms of forces.

Consider, for example, the process encountered in the statistical-hydrodynamical theory of multiple particle production in collisions of high-energy nucleons. We have in mind here collisions for which one finds nucleon Lorentz factors in the center-of-mass system, $\gamma_{c.m.} = 1/\sqrt{1 - (v^2/c^2)}$, of the order of 100 or much more. At such energies, the nucleon, which at rest has a spherical form with a characteristic radius $R \sim 10^{-13}$ cm, becomes a thin pancake in the c.m.s. with thickness $d \sim R/\gamma_{c.m.}$. Fermi assumed that any collisions of such pancakes are completely stopped as a result of the strong interaction and that their entire energy is concentrated within a region with thickness of order d (Fig. 2). At this moment, all the parts of the system have velocity zero. Subsequently, the stopping process was analyzed rigorously within the framework of the hydrodynamical model,^[21] as the outcome of the propagation of shock waves, and relativistic hydrodynamics was used. Here again there is a moment when practically all the matter is at rest (apart from a small part of it which begins to escape into the vacuum from each end of the system). It should be stressed that, by taking into account the symmetry of the problem, we may imagine that the colliding particles are separated by a wall through which matter cannot penetrate, so that the matter of each nucleon is contained in its own subspace and does not mix with the matter of the other nucleon. According to Fermi's assumption, the high energy density during this stage brings about the production of a large number of new hadrons, which in fact carry away the entire energy. However, as observed by Pomeranchuk, the produced hadrons should interact with each other as they are emitted. According to this idea, Landau constructed an elegant theory of expansion, cooling, and finally decay of the very dense matter, regarded as a continuous medium. This theory makes use of the equations of relativistic hydrodynamics and thermodynamics, and the expansion naturally takes place gradually, without the velocity ever exceeding the velocity of light.^[21]

Unfortunately, we do not yet know whether such a process, in which the colliding initial hadron-pancakes are completely stopped, occurs in nature (nevertheless, the example is completely rigorous, at least as a "gedanken experiment"). Another point is important here. If this process takes place, the two nucleons are by no means instantaneously restored to their initial form after their

initial motions are mutually stopped—a continuous and dynamically calculable process takes place.

Landau's hydrodynamical theory has been in existence for 20 years and has been elaborated, discussed and applied in many dozens of papers. Nevertheless, if one were to ask many of the physicists who have used this theory why the hadrons, after being stopped, do not have the spherical form which they must have at rest—indeed, they are at rest at this moment—the answers will often be devious and obscure. Consequently, an understanding of the role of the dynamics of the Lorentz contraction of lengths and the retardation of clocks is also of importance in the day-to-day practice of physicists whenever it is necessary to calculate a real transition of a system to a new state of motion.

Another colorful example has recently been considered: the change in the charge density (and the change in the dimensions of the entire system) in a thin planar layer of charged particles when an electromagnetic wave is normally incident on it.^[22] Again, it is clear here that the process of establishing the final constant velocity of all the charges (and accordingly the value of the density which satisfies the Lorentz contraction of the entire system) requires a dynamical analysis.

It is sometimes asked whether non-equilibrium motion can be considered in the framework of the special theory of relativity. This is, of course, a very strange question. Indeed, it is for just this purpose that there exist relativistically correct, covariant equations of motion, which in principle enable us to study arbitrary motion, including the motion of complex systems. It is another matter that, while the acceleration lasts and while external forces are acting (and also for a certain time after that; see below), we cannot, in general, apply the formulas for transforming length and time to the body as a whole at each particular moment of time. For example, if an accelerated clock has velocity v at a particular moment, an interval of time $d\tau'$ indicated by this clock is in general by no means equal to $d\tau_0\sqrt{1 - (v^2/c^2)}$, where $d\tau_0$ is the corresponding interval of time for the clock at rest, and the reading of the clock is by no means given by the Lorentz transformation of time for the given v . Everything depends on the construction of the clock and on the regime of acceleration. Indeed, during this period the clock experiences varying stresses, which are different in different elements of the clock, etc.⁹⁾ In exactly the same way, the length of an accelerated rod, when its center of mass, for example, has velocity v at a given moment of time, is not determined by the Lorentz contraction for this v —indeed, elastic waves propagate along the rod, etc.

Moreover, even after the external force has ceased to act, a certain time is required—sometimes a very long time—for the internal state of the body to come to

⁹⁾We have $d\tau' = d\tau_0\sqrt{1 - (v^2/c^2)}$ only for sufficiently slow acceleration, in which case τ' coincides with the so-called "proper time." But "in general, the acceleration affects the rate of the clock. It is only when the acceleration is sufficiently small, i.e., when the curvature of the world line is sufficiently small, that the proper time has this direct physical significance. Where the line is drawn depends on the properties of the clock. Nevertheless, the proper time defined by the formula ... [$d\tau' = d\tau_0\sqrt{1 - (v^2/c^2)}$]. —E.F.] is a useful mathematical concept" ([16], p. 76; perhaps it would be better to say that it expresses a practically useful limiting and idealized quantity, which in very many cases is an excellent approximation to the actually observed reading of the clock).

equilibrium and to be fully characterized by some constant velocity v which is common to all the parts of the body.

A good example here is the proper electromagnetic field of a rapidly moving charge such as an electron (Fig. 3). For uniform motion, when the internal state of the system is entirely stationary, the field must be an ellipsoid for which the semi-axes of any equipotential surface are in the ratio $\sqrt{1 - (v^2/c^2)}$. But if such an electron experienced an abrupt acceleration, for example, having been scattered at a large angle, then it will be a long time before it has such a field, even while already moving with constant velocity v . As is readily shown from the expressions for the Liénard-Wiechert fields (or even simply from the fact that the fields propagate with a finite velocity in the rest system of the electron), the electron may still be "bare" (more precisely, "partially bare") for a long time, with the field appearing only gradually. At a distance y from the axis of motion, the field of the electron appears only when it traverses a distance $l \sim y/\sqrt{1 - (v^2/c^2)}$. In particular, at a distance of the order of the Compton wavelength, $y \approx 4 \times 10^{-11}$ cm, the field for an electron of energy 10^{16} eV (encountered in cosmic rays) appears only when it traverses a distance (already in uniform motion!) of about 1 cm (this is also so in the quantum electrodynamic case, but there the field appears in a statistically discontinuous way, with a probability of order unity in traversing the same distance l). At a distance of 1 cm, the field of an electron of energy 10^{11} eV appears only when it traverses 2 km. This effect occurs in particular (well observed and studied) phenomena because a "bare" electron interacts with the other particles along its path differently than a normal "dressed" electron. For example, its bremsstrahlung for the new interaction is very different from that of a normal electron of the same velocity but which has had enough time after its acceleration to become "dressed," i.e., to come into an equilibrium stationary state with its field (the whole problem is analyzed in detail in ^[23]).

In this connection, it is appropriate to return to the question of the relationship between the readings of a real clock and the "proper time" for uniform motion. According to what we have just said, they coincide only if the acceleration is infinitesimally small or if enough time has elapsed after an abrupt acceleration for the internal structure of the clock to come into equilibrium. In giving the formula for the transformation of time,

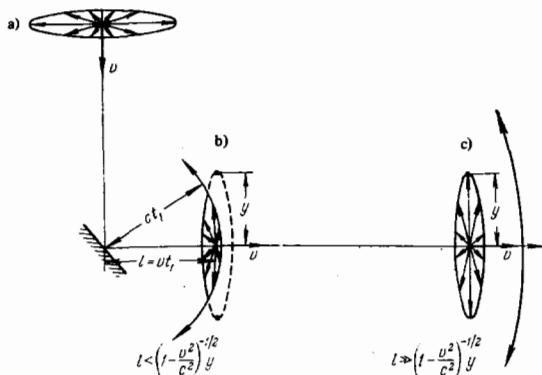

FIG. 3. The proper field of a uniformly moving electron of very high energy, for infinitely long uniform motion (a), immediately after an abrupt change in the velocity (b), and after a sufficiently long period of restoring the normal uniform field (c).

Einstein wrote: "It is immediately clear that this result is also obtained when the clock moves from A to B along any broken line" (^[15], p. 19; this statement was later extended to any broken world line, when v is different on different segments). Strictly speaking, this statement must be made more precise. After each break, the usual formula for transforming time in the case of constant velocity v cannot be applied for an interval of time $\Delta\tau' = \Delta\tau_0/\sqrt{1 - (v^2/c^2)}$ (cf. Fig. 3), where $\Delta\tau_0$ is the time in the proper system required for the clock to "relax" after its acceleration (after the break in the world line). Consequently, if the time of motion along a straight line segment is comparable with $\Delta\tau'$, then the formula obtained by summing over these segments, $\tau' = \sum \tau_0^{(i)}/\sqrt{1 - (v^2/c^2)}$, where $\tau_0^{(i)}$ is the proper time of motion along the i -th segment, is completely incorrect for a physical system with such a "relaxation" time $\Delta\tau'$. This applies equally when these arguments are extended to a curved world line.

In the twin paradox, for example in the simplest case of two uniform motions "away" and "back," one must neglect the displacements in time which occur during the periods of the initial acceleration, the reversal, and the final deceleration. They cannot be calculated in the general case, as they depend on the construction of the clocks (twins) and the regime of acceleration. However, they may be neglected because they are finite and the intervals of uniform motion can be made arbitrarily long. As we have seen, one must also neglect the displacements in time after each of the three accelerations, when the system is "relaxing" while already in uniform motion as a whole. The criterion for these displacements to be negligible is obvious: the proper time $\Delta\tau_0$ spent in "relaxation" of the system must be much less than the proper time τ_0 spent in uniform motion (in the example of Fig. 3, if the field of the electron at a distance of order y from the axis of motion is important for the operation of the "clock," we have $\Delta\tau_0 \sim y/c$).

8. THE "DYNAMICAL INTERPRETATION" AND THE GENERAL PRINCIPLES OF THE THEORY OF RELATIVITY

The experience of discussions shows that the "force" interpretation meets with objections mainly because of its association with repeated attempts to use it as a basis for arguments against the theory of relativity. We have seen that such objections are actually invalid. The description of the relativistic contraction of rods and retardation of clocks as a real process due to the action (in particular, the redistribution) of real and independently measurable forces is physically correct and fully in accord with the general principles and specific formulas of the theory of relativity. However, both before and after Einstein's discovery of the general principles, attempts were made to restrict the considerations to concrete dynamical or static calculations. In the early period, this was the quest for the ether and for absolute space.

In relatively recent times, one of the best developed attempts within the new framework was made by L. Janossy. In a lengthy paper, ^[24] he showed in detail by a number of examples how both relativistic effects emerge from concrete (physically correct) models for processes. For example, he showed that a single-electron atom constitutes a clock whose rate changes when the atom is set in motion, as a result of the growth of

mass with velocity. These examples are no doubt of pedagogical value in themselves. However, the conclusion of L. Janossy—a certain scepticism about the theory of relativity—is hardly justified. He believes, for example, that whenever new forms of force are discovered one must again and again convince oneself that the Lorentz transformations are valid, and that the existence of a dynamical interpretation of those relativistic effects which we can already calculate may render the theory of relativity, like the general theory, unnecessary. Thus, the dynamical interpretation is in essence again set in opposition here to the theory of relativity. The author is by no means claiming here that this theory is, a priori, either wrong or useless, but is merely keeping it under constant suspicion.¹⁰⁾

Undoubtedly, nobody will dare to claim that the theory of relativity will remain unchanged for all time. New experimental facts which call for modifications may emerge. However, if this does happen, it will be because the theory is superseded by a more universal one and remains a limiting case of this more general theoretical construct (just as the special theory of relativity was superseded by the general theory). But the main point is that the dynamical explanation of so-called kinematic effects in no way weakens the principles of the theory of relativity and is not at all beyond the scope of this theory, but constitutes a limiting element of it; moreover, as we have seen, it is, in the opinion of Einstein himself, essential. The analysis of the concrete examples undertaken by L. Janossy may serve as a further illustration of the fact that a clear understanding of the place and role of the dynamical approach helps to dispel the nagging doubts.

I. E. Tamm wrote (^[25], p. 184):

“The postulates of the theory of relativity, like the law of conservation of energy, allow us to explain a number of exact characteristics of physical phenomena in cases when we do not know the exact laws of force describing the interaction of the elements of a body . . . , or when an exact calculation of the result of the action of known forces . . . is impracticable because of its complexity. Of course, very many physical problems cannot be solved purely on the basis of general regularities, but require a detailed analysis.”

The need for repeated tests of the validity of the conclusions of the theory of relativity cannot be altered by any arguments, quite apart from the fact that the theory of relativity is no different in this respect from a number of other fundamental theories. In fact, it is equally justified (or unjustified) to insist on carrying out special experiments to test the law of conservation of energy, the law of increase of entropy, etc. It is always possible in principle, purely logically, that such laws are violated. However, the validity of the dynamical interpretation of the kinematic formulas of the theory of relativity adds nothing here.

9. CONCLUSIONS

In conclusion, we may pose another question. If everything is so simple and if the “force” and, in particular, the dynamical interpretation is valid, why is it that

opinions to this effect are so rarely encountered among authorities such as Einstein, Pauli, von Laue and Möller and even absent in the works of other prominent physicists? Most likely, this problem is one of elementary clarity to all of them.¹¹⁾ The dynamical interpretation followed with too much certainty from the previous history of the problem and from the works of Lorentz, Poincaré, etc. For Einstein, the problem was different: to find the general principle which guarantees that the contraction of rods and retardation of clocks is universal, independently of their physical properties, the types of fields which act and the regime of acceleration, and which is also in accord with the fact that absolute motion is unobservable. This principle is the covariance of the equations of motion with respect to the Lorentz transformation and the indivisibility of space-time into independent space and time—the principle of relativity, in conjunction with the independence of the velocity of light on the velocity of the source. It was revealed by Einstein in his analysis of the measuring process, in his definition of the concepts of length and interval of time, and in his discovery of the relativity of simultaneity. Einstein’s contribution, thanks to which the theory of relativity bears his name, amounts to the discovery and formulation of a new “limiting principle,” which has been placed on an equal footing with the principle of conservation of energy and other principles in the same class. It was this discovery of Einstein that was so striking to physicists that all of them, in their expositions of the theory of relativity, present mainly this aspect of his work, while the problem of the dynamical interpretation of relativistic effects does not seem to them worthy of special attention.

To summarize, we can say the following. To the question “Can the relativistic contraction of lengths and time dilation be considered the result of a dynamical process (or reduced to an equilibrium of forces which changes in character as the velocity increases)?” we answer:

“Yes, but if we are interested only in a state of uniform relative motion of a body and a coordinate system, this is not necessary. It is not necessary because the relativistic kinematic approach is not only simpler and leads more directly to its goal, but it is also more satisfactory: the reduction to the action of forces, to atomic structure and to the equations of motion may obscure the universal character of the effect and its dependence on the properties of space-time which are revealed by the principle of relativity.

However, it must be borne in mind that this interpretation of the effect is possible, and it is necessary in the case of processes involving a transition from one state of uniform motion to another, particularly when this transition is accompanied by changes in the internal structure and other properties of the body. We must then make use of the equations of motion, the specific properties of the material, etc. In the light of this more general situation, the contraction of length and retardation of clocks in the case of uniform motion appears as a special case for which it is sufficient to employ the kinematics of the theory of relativity, just as it is sufficient to employ the law of conservation of energy to determine the height reached by a projected stone.

¹⁰⁾In the pre-reform Russian court there existed, in addition to the verdicts “innocent” and “guilty,” the additional formula “innocent, but remaining under suspicion” (which was, in particular, applied to Sukhovo-Kobylin).

¹¹⁾Landau did not even begin to explain in his paper on the hydrodynamical theory why we find the thin petal in Fig. 2b at the initial moment of hydrodynamic expansion instead of two spheres.

This situation can also be illustrated by the following example.

When the idea of a local interaction of electric charges through the medium of the electromagnetic field was proposed as an alternative to action at a distance, it was impossible to choose between the two concepts while remaining entirely within the framework of electrostatics. This choice could be made only by analyzing a more general situation. It was conventional to give the following argument. Suppose that we transmit a radio signal, destroy the transmitter and then construct a receiver at another position before the signal reaches this point. It is obvious that energy was stored in the field during the period when neither the transmitter nor the receiver existed. We have a somewhat similar situation in the relativistic problem with which we are concerned: the reality of the forces which govern the contraction of rods and the retardation of clocks is revealed only in processes in which a contracted state (or a retarded rate of the process) is established. We need not consider these forces or know anything about them if we are interested in only the integral effect—the differences between lengths and intervals of time defined with respect to different inertial coordinate systems. It is sufficient in this case to make use of the general “limiting” principle, on an equal footing with the law of conservation of energy and the law of non-decreasing entropy.

We see that even the simple question of what to consider more fundamental and more “elementary” (Möller), the relativistic contraction of length or the covariant equations of motion, does not admit a unique answer.

In the case of the law of conservation of energy for a conservative system, we can, on the one hand, regard the equations of motion as more fundamental than the conservation law. In fact, the latter is merely one of the consequences of the equations of motion—one of their integrals—and is therefore much more limited in content. It is enough to introduce a time-dependent external field, and it becomes ineffective; we are obliged to use the equations of motion. On the other hand, this law is of such great generality and, what is more, it expresses such a fundamental property of time—its homogeneity (the invariance of the Lagrangian under displacements in time)—that there are sufficient grounds for regarding it as more fundamental than the equations of motion, which must obey this law.

In exactly the same way, the relativistically covariant equations of motion and the laws of dynamics are much broader than one limiting property of entire systems—the contraction of length and retardation of time in the case of uniform motion. But if there is the slightest nonuniformity in the motion of a clock, its reading, strictly speaking, no longer corresponds to the relativistic retardation for its particular—instantaneous—velocity. This reading will depend on the construction of the clock and the regime of its acceleration. The reading of the clock can be calculated (at least in principle) entirely from the equations of motion. We may therefore suppose that these equations are more fundamental than the Lorentz formulas for the time dilation and contraction of length, which give only the limiting values of the effect for the case of completely uniform motion which lasts for a sufficiently long time. But on the other hand, these formulas express such a general property of space and time—the indivisibility of the space-time continuum into independent continua of space and time—that there

are also grounds for regarding these formulas as more fundamental.

¹H. A. Lorentz, *Die Relativitätstheorie für gleichförmige Translationen*, Leipzig, Akad. Verlagsgesellschaft, 1929.

²J. Terrel, *Phys. Rev.* **116**, 1041 (1959).

³R. Penrose, *Proc. Cambridge Phil. Soc.* **55**, 137 (1959).

⁴V. Weisskopf, *Phys. Today* **13**, 24 (1960) [Russ. Transl., *Usp. Fiz. Nauk* **64**, 183 (1964)].

⁵A. Einstein, *The Electrodynamics of Moving Bodies*, *Collected Works* (in Russian) Vol. 1, Moscow, Nauka, 1965, p. 7.

⁶L. I. Mandel'shtam, *Lektsii po teorii otnositel'nosti*, *Sobranie trudov* (Lectures on the Theory of Relativity, *Collected Works*), Vol. 5, Moscow-Leningrad, USSR Academy of Sciences, 1950.

⁷Ya. A. Smorodinskiĭ and V. A. Ugarov, in: *Ėĭnshteĭnovskii sbornik* (Einstein's *Collected Works*), 1972, Moscow, Nauka, 1974, p. 237.

⁸A. I. Zhukov, *Vvedenie v teoriyu otnositel'nosti* (Introduction to the Theory of Relativity), Moscow, Fizmatgiz, 1961.

⁹M. Gardner, *Relativity Theory for the Million*, Macmillan, 1962 [Russ. Transl., Moscow, Atomizdat, 1965].

¹⁰V. Kurganov, *Vvedenie v teoriyu otnositel'nosti* (Introduction to the Theory of Relativity) (translated from the French), Moscow, Mir, 1968.

¹¹N. Mitskevich, Epilogue in the book [10].

¹²W. H. McCrea, *Relativity Physics*, London, Methuen, 1935.

¹³W. Pauli, *The Theory of Relativity*, Pergamon, 1958, translated from the German [Russ. Transl., Moscow, Gostekhizdat, 1947].

¹⁴A. Einstein, *Sobranie trudov* (Collected Works), Vol. IV, Moscow, Nauka, 1967, p. 46.

¹⁵A. Einstein, *ibid.*, p. 42.

¹⁶M. von Laue, *Die Relativitätstheorie*, Vol. 1, 1921.

¹⁷C. Möller, *The Theory of Relativity*, Oxford Univ. Press, 1955.

¹⁸A. Einstein, *Avtobiograficheskie zametki*, *Sobranie trudov* (Autobiographical Notes, *Collected Works*), Vol. IV, Moscow, Nauka, 1967, p. 280.

¹⁹Yu. Sokolovskii, *Teoriya otnositel'nosti v élementarnom izlozhenii* (An Elementary Account of the Theory of Relativity), Kharkov, 1960.

²⁰L. D. Landau and E. M. Lifshitz, *Mekhanika sploshnykh sred* (Fluid Mechanics), Moscow, Gostekhizdat, 1953 [Addison-Wesley, 1958].

²¹S. Z. Belen'kiĭ and L. D. Landau, *Usp. Fiz. Nauk* **56**, 309 (1955).

²²S. I. Syrovatskiĭ, A Possible Delay in the Relativistic Contraction of Moving Bodies (Report at a seminar at FIAN, November, 1974), *Usp. Fiz. Nauk* (1976).

²³E. L. Feinberg, *Zh. Eksp. Teor. Fiz.* **50**, 202 (1966) [*Sov. Phys.-JETP* **23**, 132 (1966)] (quantum electrodynamical analysis); in: *Problemy teoreticheskoi fiziki* (sbornik stateĭ pamyati I. E. Tamma) [Problems of Theoretical Physics (Collection of Papers to the Memory of I. E. Tamm)], Moscow, Nauka, 1972; *Trudy Sukhumskoĭ shkoly molodykh uchenykh* (Proc. of the Sukhumi School for Young Scientists), September, 1972, Dubna, JINR, 1972, p. 56; Preprint FIAN SSSR No. 166, Moscow, 1972 (the classical case and application to the proper meson field of high-energy hadrons).

²⁴L. Janossy, *Usp. Fiz. Nauk* **62**, 149 (1957) [AEC Tr.-3972, p. 101].

²⁵I. E. Tamm, *ibid.*, p. 183 [tr. p. 149].

Translated by N. M. Queen